

ANNEX 12

.*

FTTx OSP and ISP

Specifications and Guidelines

for

Kenya FTTx NETWORK

CONTENTS

1	Introduction to FTTx Network	3
2	Regulations for FTTx Network Design and Deployment.....	4
3	ODN Specifications	5
4	ODN Design Rules	13
5	FTTx OSP Specifications	14
6	FTTx ISP Specifications.....	16

LIST OF FIGURES

Figure 1-1: FTTx Network Description	3
Figure 3-1: ODN Description.....	7
Figure 3-2: 2 Levels of Symmetrical 1: 8 Cascaded PON Splitting Architecture	8
Figure 3-3: 5 Cascaded Levels of Hybrid Symmetrical and Asymmetrical PON Splitting Architecture.....	9
Figure 3-4: 4 Cascaded Levels of Hybrid Symmetrical and Asymmetrical PON Splitting Architecture.....	10

1 Introduction to FTTx Network

1.1 FTTx Network is an optical access network for delivery of triple-play (internet broadband, telephony and television) services as well as pseudowires to customers. FTTx (Fiber to the 'x') is general term where 'x' represents the termination point of the optical access network and can be 'Home' for residential customers or 'Office' for business customers.

1.2 FTTx consists of two layers

- 1) Optical Distribution Network (ODN) as passive layer.
- 2) Optical Line Terminal (OLT) and Optical Network Terminals (ONT) as active layer.

1.3 The FTTx Network construction consists of the Outside Plant (OSP) and the Inside Plant (ISP) as illustrated in Figure 1-1 Error! Reference source not found.:

- 1) The OLT is usually located at a central office, cellsite or in a technical room within a building.
- 2) The FTTx OSP consists of ODN transport networks from which ODN distribution networks span out at distribution hubs and provide fiber access to homes and offices at Optical Distribution Points (ODP).
- 3) The FTTx ISP consists of the passive network that provides last mile fiber connections to homes and offices.
- 4) The ONT is installed at the subscriber's premises and delivers triple play services through both wireless and wired connections.

Figure 1-1: FTTx Network Description

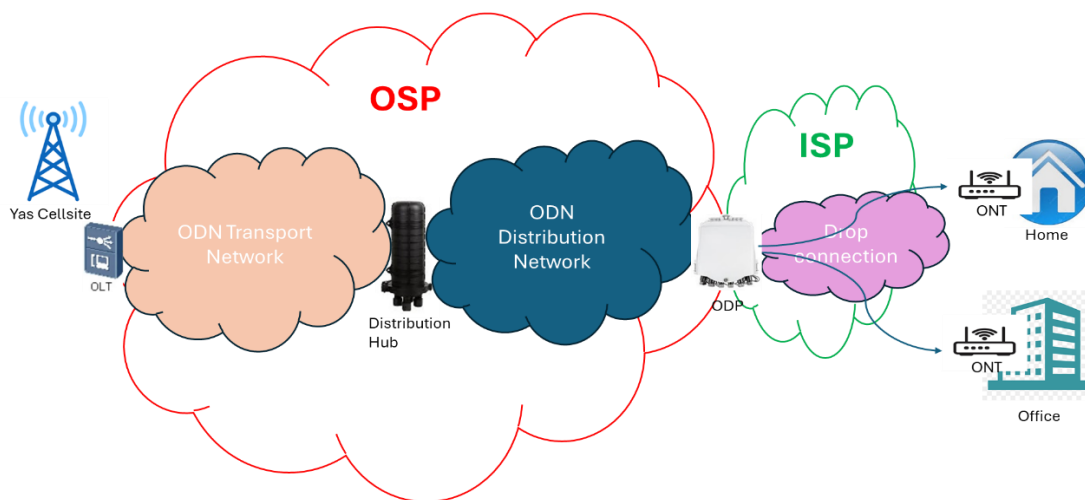

2 Regulations for FTTx Network Design and Deployment

2.1 All FTTx OSP and ISP design proposed, and subsequent deployment shall comply with the following guides/terms and conditions:

- 1) *The local regulation authority Guidelines for Aerial Fiber Optic Cables Deployment* where applicable.
- 2) *Pole Setup Guideline for Operators Infrastructure Sharing*, of Annex 2.
- 3) Terms and Conditions of Right of Ways in the country.

3 ODN Specifications

- 3.1 Wananchi** requires an ODN design which is scalable, expandable and extendable for cost effective greenfield implementation of FTTx network in both urban and rural areas of Kenya.
- 3.2** The ODN shall consist of the following optical elements as illustrated in [Figure 3-1](#):
- 1) PON splitters
 - 2) Optical Distribution Frame (ODF)
 - 3) FO transport and distribution cables
 - 4) Optical enclosures
 - 5) Optical Distribution Points (ODP)
 - 6) FO drop cables
 - 7) Access Terminal Box (ATB)
- 3.3** The ODN can be all pre-connectorized, all traditional or hybrid solution types.
- 3.3.1** All pre-connectorized ODN solution consists of optical enclosures and ODP with outside pre-connectorized adapters connected with FO cables with pre-connectorized connectors in both transport and distribution segments of the ODN without any splicing operations during deployment.
- 3.3.2** All traditional ODN solutions consist of traditional FO cables, splicing enclosures and ODP with all connected through optical splicing during deployment in both transport and distribution segments of the ODN.
- 3.3.3** In hybrid pre-connectorized and traditional ODN solutions, the distribution network consists of pre-connectorized solutions of FO cables, optical enclosures and ODP while the transport network consists of traditional solutions of FO cables and splicing enclosures.
- 3.4** The ODN solution shall be applicable to aerial, underground, on wall or in-building installations.
- 3.5** ODN PON Splitters shall abide by the following specifications:
- 3.5.1** The ODN design shall meet the specifications of Class C ODN as per ITU-T G.984.x series with an aggregated PON splitting ratio of 1:64.
- 3.5.2** The ODN design shall have a minimum of two cascaded splitting stages using symmetrical, asymmetrical or both splitters to achieve the aggregated PON splitting ratio of 1:64. Typical architectures of ODN designs with aggregated PON splitting ratio of 1:64 are illustrated in [Figure 3-2](#), [Figure 3-3](#) and [Figure 3-4](#).
- 3.5.3** The first level PON splitters shall be all located in splicing enclosures or ODP while the subsequent levels PON splitters as per chosen architecture shall all be located in ODP.

3.5.4 The PON splitters shall use TIA-598 color coding standard wherever FO splicing is required.

Figure 3-1: ODN Description

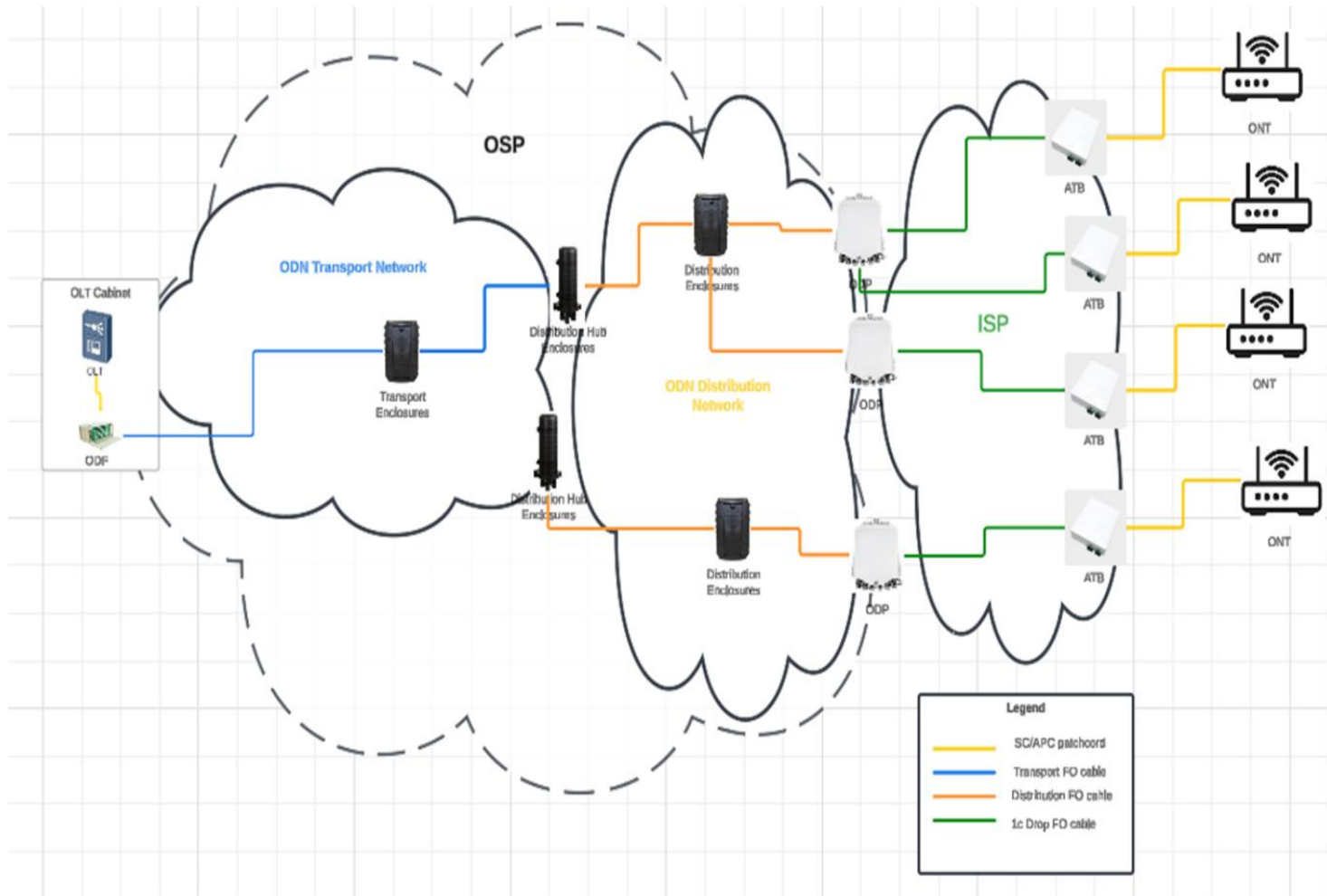

Figure 3-2: 2 Levels of Symmetrical 1: 8 Cascaded PON Splitting Architecture

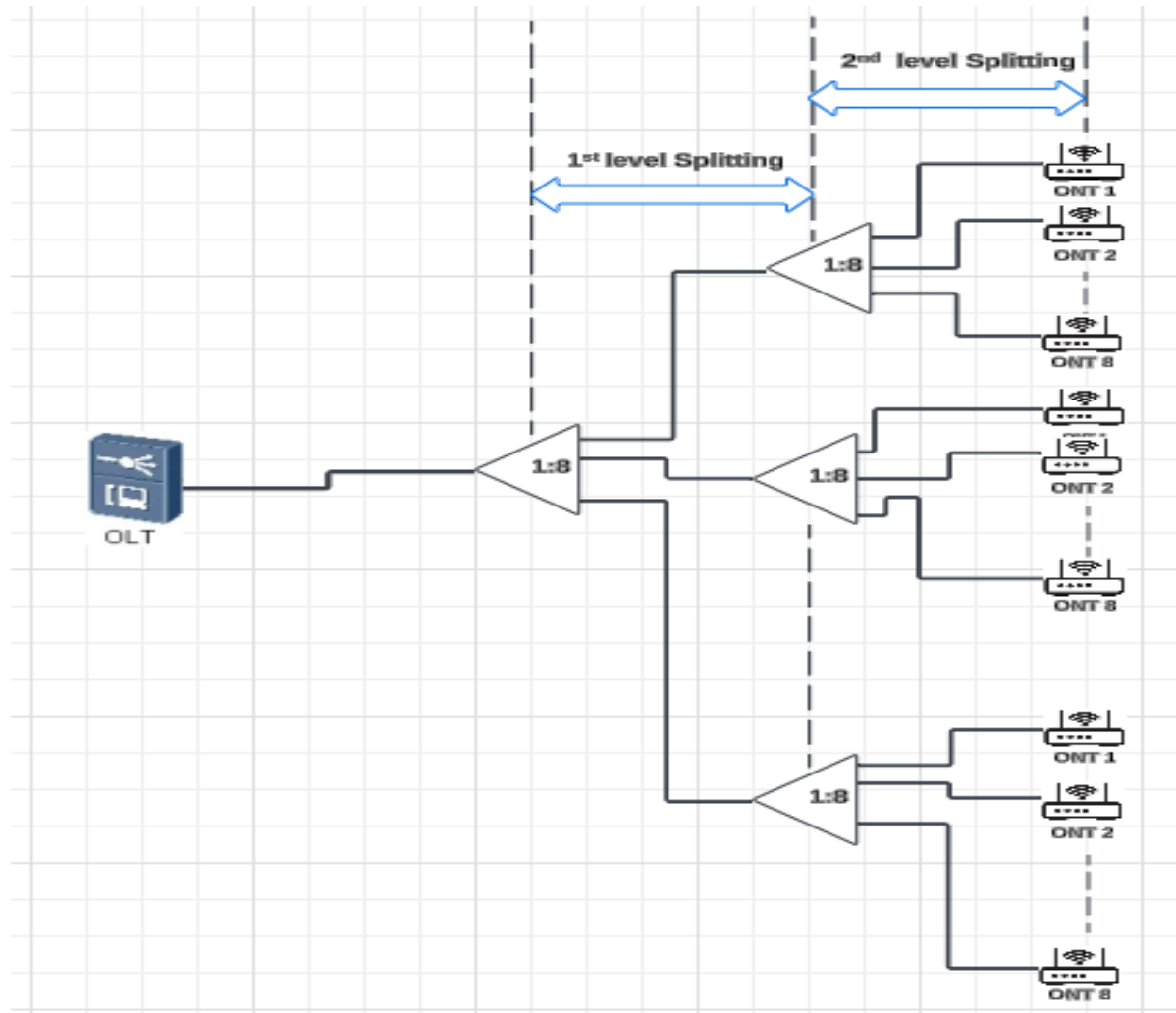

Figure 3-3: 5 Cascaded Levels of Hybrid Symmetrical and Asymmetrical PON Splitting Architecture

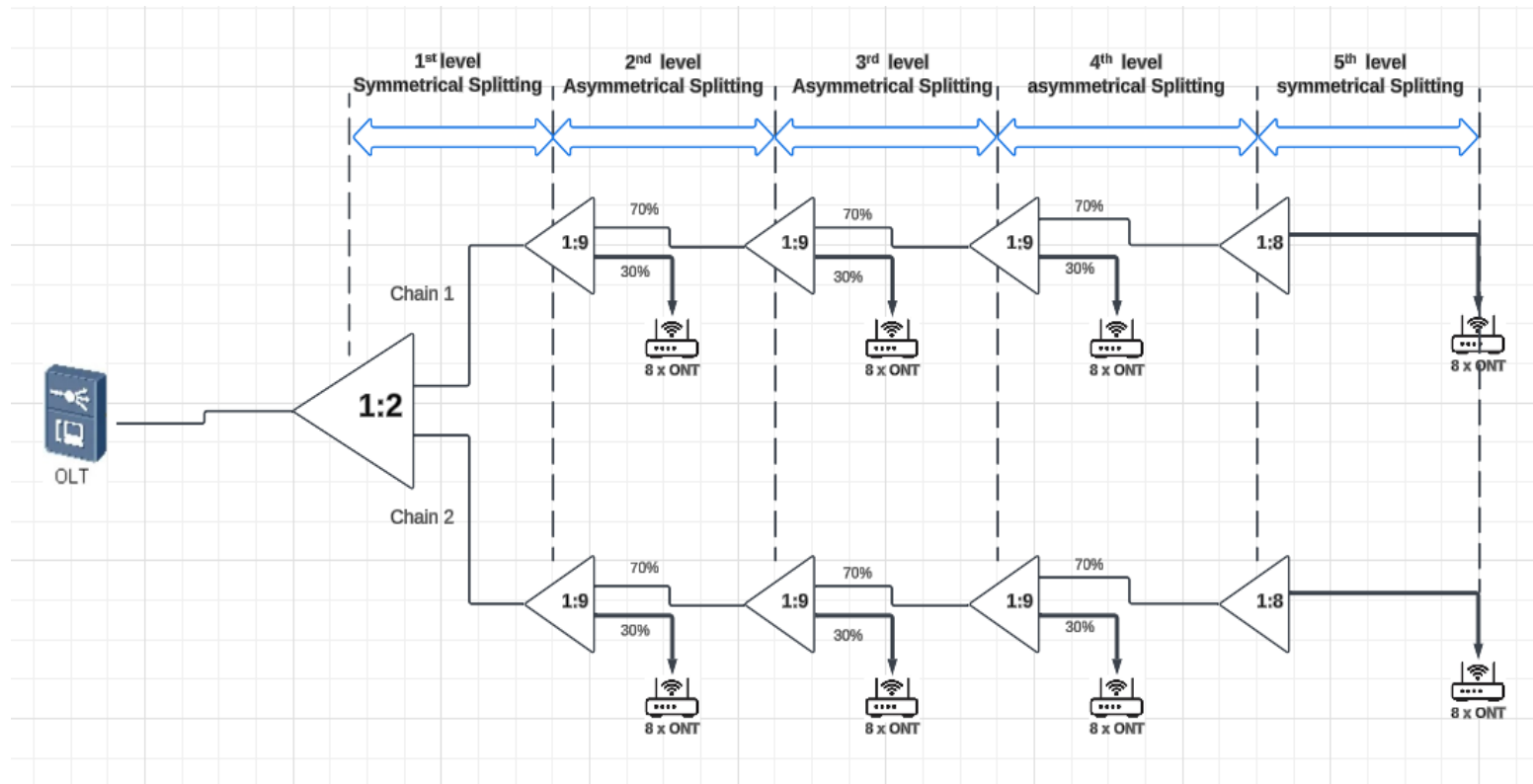
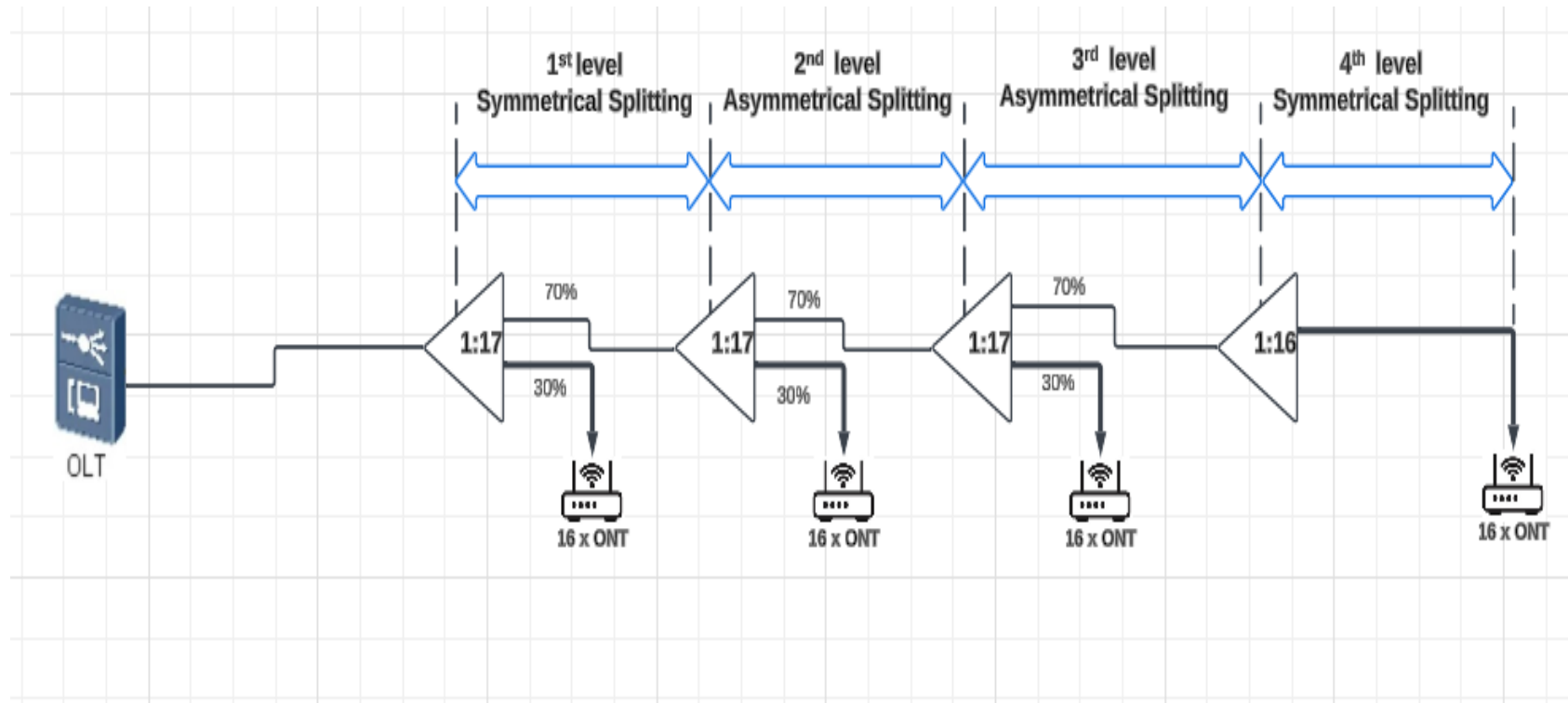

Figure 3-4: 4 Cascaded Levels of Hybrid Symmetrical and Asymmetrical PON Splitting Architecture



- 3.6** The ODF model shall be of following specifications for termination of ODN transport FO cables:
- 1) Of standard sizes for installation in standard racks inside OLT cabinet.
 - 2) Of rotary type.
 - 3) SC/APC adapters.
 - 4) 24c, 48c, 96c or 144c capacities as required for optimum design.
- 3.7** FO transport and distribution cables models shall be of ITU-T G.652D standard, and shall be suitable for aerial, underground, on wall and in-building installations.
- 3.7.1** Traditional FO Cables as required shall comply with the following specifications:
- 1) Micro-module model.
 - 2) TIA-598 color coding standard.
 - 3) 12 cores, 24 core, 48 core, 96 core or 144 core capacities as required for optimum design.
- 3.7.2** Pre-connectorized FO Cables as specified in Section 3.3 shall be of 1 core or 2 core capacity and equipped with SC/APC connectors.
- 3.7.3** All FO transport and distribution cables shall be labelled and have the color as specified in the annex 1; along with standard labelling of manufacturer, cable type and capacities and length indicators.
- 3.8** Optical enclosures shall be of suitable model for on pole, on wall and in-building installations whether in outdoor or indoor deployment and rated for water tightness and against insects' infestation.
- 3.8.1** Optical enclosures shall be splicing or non-splicing enclosures as required by traditional ODN or pre-connectorized ODN solutions respectively.
- 3.8.2** Optical enclosures shall house first level PON splitters wherever applicable as per chosen architecture of ODN solution. E.g. first level splitters of architecture illustrated in Figure 3-2**Error! Reference source not found.** and Figure 3-3 are located in distribution hub enclosures illustrated in Figure 1-1 **Error! Reference source not found.**
- 3.8.3** Optical enclosures shall be used for FO concatenation or branching in both transport and distribution networks.
- 3.8.4** Optical enclosures shall be equipped:
- 1) External SC/APC adapters for connection with pre-connectorized FO cables as required for pre-connectorized ODN solutions.
 - 2) Cassette labelling for fiber identification wherever used for optical splicing as required in traditional ODN solutions.

- 3.9** ODP shall be of suitable model for pole, on wall and in-building installations whether in outdoor or indoor deployment and rated for water tightness and against insects' infestation.
- 3.9.1** The ODP model shall be either of two capacities for drop connections as per following specifications:
- 1) 16 drop connections requiring no expansion
 - 2) 8 drop connections with a spare fiber enabling future expansion for 8 additional drop connections.
- 3.9.2** The ODP model shall be equipped with:
- 1) External SC/APC adapters for connection with pre-connectorized FO cables as required in pre-connectorized ODN solutions.
 - 2) Cassette labelling for fiber identification wherever used for optical splicing as required in traditional ODN solutions.
- 3.10** FO drop cables model shall be of ITU-T G.657A standard, 1 core FO capacity and shall be suitable for aerial, underground, on wall, and in-building installations when connecting ODP to ATB.
- 3.10.1** FO drop cables model shall be pre-connectorized with SC/APC connectors at one end for connection with ODP model used in pre-connectorized ODN solutions specified in Section 3.3 and adapted for use of FO Field Assembly Connectors of SC/APC type to connect with ATB located in customer premises.
- 3.10.2** FO drop cables model shall be adapted for use of FO Field Assembly Connectors of SC/APC type for connecting both ODP and ATB in traditional ODN solutions specified in Section 3.3.
- 3.10.3** FO drop cables model shall be specified for aerial installation up to 70m span length.
- 3.10.4** FO drop cables shall be labelled and have the color as specified in the annex 1 along with standard labelling of manufacturer, cable capacity and length indicators.
- 3.11** ATB model shall be rated for indoor use, on wall or desktop mountable, within subscriber premises and on-wall installation:
- 3.11.1** ATB shall be equipped with an SC/APC coupler for connecting FO drop cables with ONT through an optical patchcord.
- 3.11.2** ATB shall be adapted for use of FO Field Assembly Connectors of SC/APC type for termination of FO drop cables.

4 ODN Design Rules

4.1 ODN Design shall adhere to ODP Design Occupancy Rules and Distribution Hub Capacity Rules to ensure expandability of ODN for cost-effective scalability of the FTTx Network.

4.2 ODP Design Occupancy Rules

4.2.1 The number of **Potential Homes** assigned on average per ODP in an ODN shall be **equal to 50%** of the ODP drop capacity.

4.2.2 For ODP model of 16 drop capacity as specified in 3.9.1, the number of **Potential Homes** assigned per ODP shall be equal to 8.

4.2.3 For ODP model of 8 drop capacity and with spare 1 core capacity as specified in Section 3.9.1, the number of **Potential Homes** assigned per ODP shall be equal to 8.

4.3 Distribution Hub Capacity Rule

4.3.1 Each distribution hub shall be provisioned with **70% spare capacity** for expansion of distribution network.

4.3.2 For ODN architecture with first level PON splitters located in the distribution hub enclosure, e.g. ODN architectures illustrated in [Figure 3-2](#) and [Figure 3-3](#), the number of spare PON splitters shall correspond to the 50% spare capacity specified in Section 4.3.1.

4.3.3 For ODN architecture without first level PON splitters in the distribution hub enclosure as illustrated in [Figure 3-4](#), **the 70% spare capacity** required in Section 4.3.1. shall be provisioned in terms of FO cables output for distribution network.

5 FTTx OSP Specifications

- 5.1** The FTTx OSP consists of the transport and distribution segments of the ODN as well as their support infrastructure for aerial, underground, on wall and in-building installations.
- 5.2** In addition to ODN elements specified in Section 3, FTTx OSP is made up of the following, but not limited to, infrastructure:
- 1) Underground network consisting of ducts, manholes, handholes, markers and pole risers.
 - 2) Telecom wooden poles of 8m and 9m heights.
 - 3) Aerial accessories such as anchor clamps, suspension clamps, coiling cross, crossbars, etc.
 - 4) Special installations such as concrete poles or cable trays.
- 5.3** FTTx OSP design shall comply with the following requirements:
- 1) *Guidelines for Aerial Fiber Optic Cables Deployment – where applicable.*
 - 2) *Pole Setup Guideline for Operators Infrastructure Sharing, Annex 2. Electrical Pole provider standards.*
 - 3) Terms and Conditions of Right of Ways.
- 5.4** The FTTx OSP shall be mostly aerial installation for cost-effective implementation of FTTx network with underground installation limited to wherever required by Right of Ways and special installations limited to exceptional cases.
- 5.5** Underground network infrastructure shall be constructed based on standards acceptable to **Wananchi**.
- 5.5.1** HDPE 40/35 duct shall be used as underground ducts and laid in pairs except for underground road crossings in which HDPE 110mm duct shall be used.
- 5.5.2** Horizontal Drilling Method shall be used for laying underground ducts at a depth of 1.5m in all road crossings wherever required by the Right of Ways and/or **Wananchi**.
- 5.5.3** Warning tape labelled with “**Wananchi**” shall be laid at least 1m above all underground ducts.
- 5.5.4** Manholes and/or handholes, of dimensions 1x1x1 m and 0.6x0.6x0.6 m respectively, shall be located at every 300m of any underground network segment, with a concrete marker labelled “**Wananchi**” close to the manhole or handhole and fitted with an electronic wheelmarker.
- 5.5.5** Risers at all underground to aerial transition shall consist of galvanized steel pipes rising to at least 3m above ground level and shall be properly secured at the base and using stainless-steel bands against the pole.

- 5.5.6 All FTTx OSP installations shall be underground within a cellsite with a concrete marker indicating location of FO cable entries and shall conform to TowerCo guidelines.
- 5.6 Aerial infrastructure shall consist of telecom wooden poles of 8m and 9m heights.
 - 5.6.1 8m poles shall be used for side road aerial passage while 9m poles shall be used for all aerial public road crossings.
 - 5.6.2 Span length of maximum 40m shall be used between adjacent poles.
 - 5.6.3 Minimum pole planting depth of 1/6th of the pole height or as recommended by the pole manufacturer shall be used during pole implantation.
 - 5.6.4 All implanted poles shall be in optimum proximity with respect to the **Potential Homes** to minimize use of extra last mile poles during ISP implementation.
 - 5.6.5 All aerial cables shall have a minimum clearance of 6m with respect to ground.
 - 5.6.6 All implanted poles shall be labelled with weatherproof tag using a pole identification nomenclature agreed with **Wananchi**.
- 5.7 Aerial accessories shall be used to support aerial installations of FO cables and shall be fitted on wooden poles.
 - 5.7.1 Anchor clamps and/or suspension clamps shall be used to secure and tension FO cables and shall be rated for span lengths of 40 to 70m.
 - 5.7.2 Crossbars of 13 holes shall be used to support anchor and suspension clamps and shall be fixed on poles using nuts and bolts.
 - 5.7.3 Coiling cross shall be used for arrangement of traditional FO cable coils at optical enclosures specified in Section 3.8 and OLT sites.
- 5.8 Special installations for the OSP shall be required exceptionally due to constraints on deployment or threat to network operations. Such installations can include use of concrete poles in swampy areas, specialized ducts for bridge crossing or cable trays for in-building installations.

6 FTTx ISP Specifications

- 6.1** The FTTx ISP consists of the passive layer as well as its supporting infrastructure in the last mile connection between ODP and ATB.
- 6.2** In addition to FO drop cables, FO Field Assembly Connectors and ATB specified in Section 3, FTTx ISP shall consist of the following, but not limited to, infrastructure:
 - 1) Aerial clamps, crossbars and other aerial accessories.
 - 2) Intermediary telecom wooden poles of 8m height.
- 6.3** Aerial accessories shall be used to support aerial installations of FO drop cables and shall be fitted on wooden poles.
 - 6.3.1** Aerial clamps shall be used to secure and tension FO drop cables at start, intermediary and terminal poles and shall be rated for span lengths of 40 to 70m.
 - 6.3.2** Telecom wooden poles of 8m or 9m height shall be used as intermediary poles wherever required between ODP and subscriber due to long spans or bent routes.
 - 6.3.3** Crossbars of 8 holes shall be used to support aerial clamps and shall be fixed on intermediary last mile poles and can be fixed using steel bands on poles.
 - 6.3.4** Pole of 8m height shall be the standard choice for last mile intermediary poles except for aerial public road crossings where pole of 9m height shall be used.

END OF DOCUMENT